

Partial Discharge Simulations Used for the Design of a Non-Intrusive Cable Condition Monitoring Technique

Heino van Jaarsveldt and Rupert Gouws

Faculty of Engineering: School of Electrical, Electronic and Computer Engineering, North-West University, Potchefstroom 2531, North-West, South Africa

Received: March 26, 2013 / Accepted: June 07, 2013 / Published: November 30, 2013.

Abstract: The purpose of this paper is to investigate the effect of PD (partial discharge) activity within medium voltage XLPE (cross-linked polyethylene) cables. The effect of partial discharge was studied by means of a number of simulations. The simulations were based on the well-known three capacitor model for partial discharge. An equivalent circuit was derived for partial discharge due to a single void in the insulation material of a power cable. The results obtained from the simulations will form the basis of the design process of a non-intrusive condition monitoring technique. The technique is based on the classification of discharge activity according to five levels of PD. Future work will include the improvement of the simulation model by investigating the high frequency model of a power cable as well as the statistical nature of PD activity. This will improve the accuracy of the simulation results when compared to actual measurements. The work discussed in this paper will be used to construct and calibrate a practical model which will make use of PD measurements for non-intrusive condition monitoring of medium voltage electrical cables.

Key words: Condition monitoring, non-intrusive, PD (partial discharge), XLPE (cross-linked polyethylene), void size, apparent charge.

1. Introduction

1.1 PD (Partial Discharge)

Electrical cables are an essential part of an electrical network and also play a vital role in the safety of such a network. Often high voltage cables are used for underground transmission of electricity. For this reason, the conductor must be completely isolated, other than with overhead lines where air forms part of the insulation. Due to the fact that the conductor must be completely isolated, the cables are much more expensive than normal overhead lines [1]. Research has shown that partial discharge in electrical cables is one of the main causes for insulation degradation. Partial discharges can be described as localised electric discharges that do not bridge the complete distance

between electrodes, indicating the presence of cavities as well as defects within the insulation material of electrical cables [2].

Once PD has occurred in a cable, it will continue to degrade the insulation of that cable to the point where the cable will fail. PD usually occurs due to cavities or voids within the insulation material of the electrical cable [3]. Environmental as well as operational stressors will cause electrical cables to degrade over a period of time.

This degradation is caused by electrical, chemical and mechanical stress. The degradation of the insulation materials will ultimately cause PD activity within the cable and lead to cable failure [4]. It is therefore important to be able to estimate the remaining operational life of an electrical cable by constantly monitoring the condition of that cable.

Different factors must be considered when choosing a condition monitoring technique for a specific purpose.

Corresponding author: Heino van Jaarsveldt, B. Eng. electrical and electronic engineering, masters student, research fields: condition monitoring of medium voltage power cables. E-mail: heino.van.jaarsveldt@gmail.com.

These factors include: the cable being tested, physical environment, affordability, ease of use, as well as required results obtained from tests. Certain elements must be considered in order for the chosen condition monitoring technique to be effective. The most important elements are [5]: selection of cables to be monitored, database development for monitored cables, the monitoring of the service environment, identifying expected factors leading to aging and degradation, selection of suitable condition monitoring techniques, regular test and inspection activities, periodic review and assessment of the monitored cables. The ideal condition monitoring technique can be described as a technique which adheres to a list of nine desired attributes listed in Ref. [5]. It is however not possible for a single technique to adhere to all of the desired attributes. An important attribute for a condition monitoring technique used on cables, is to be non-intrusive. The advantage of a non-intrusive technique is that measurements can be taken without the cable being taken out of operation. The major disadvantage of a non-intrusive technique is that it has significantly less sensitivity than that of intrusive techniques. Condition monitoring techniques can be divided into two main groups: in-situ techniques and laboratory techniques [5].

1.2 History of PD Research

During the early 1940s, the research for measuring and locating partial discharge began. As this was the beginning the main focus was to understand the phenomena known as partial discharge [6]. The development of PD measuring techniques started in the 1950s and 1960s. The main focus during this time was on the physical principles of degradation associated with partial discharge. This period of time is also referred to as the golden age of partial discharge. Various types of measuring techniques for the detection of partial discharge were introduced during the 1970s. These techniques include electrical, acoustic and also chemical techniques. During the 1980s and

1990s, the focus was on the ability to capture data obtained from PD measurements. This was made possible due to improved technology and also the availability of microprocessor technologies [7]. At the moment, the main focus of PD research is to refine and improve techniques for detecting discharge in electrical equipment.

1.3 Development of a PD Model

The development of electrical models to be able to study the behaviour of PD activity within the insulation of power cables started in 1932 when Germant and Philippoff developed the simplest electrical representation of a defect within the insulation. This model has a macro approach to the analysis of partial discharge and is known as the capacitive model [8]. Over the years, many improvements were added to this original model. The original model made use of a spark gap to simulate the occurrence of PD activity. The spark gap was replaced by Whitehead in 1951 by an electronically controlled device. The main focus for the improvements on the original device was to be able to more accurately simulate PD activity within the insulation material of a power cable. This focus led to the introduction of the shunt conductance of the healthy part of the insulation and the void. The shunt conductance was introduced in 1999 by Paolletti and Golubev in the article “partial discharge theory and applications to electrical systems” [9]. A number of research papers followed where a macro approach was used to study PD activity within power cables by means of different configurations of the capacitor model. Haghjoo et al. [8] made further improvements on this basic three-capacitor model in 2012. In this paper, their research did not only consider the geometric properties of the void and other internal parameters, but also the position of the void within the insulation material and the congestion of electric field lines while passing through the void [8]. The research in this paper will focus on the simulation of partial discharge within the insulation material of medium

voltage XLPE (cross-linked polyethylene) cables. The simulations will be performed by making use of a basic three-capacitor model.

2. Materials and Method

2.1 Materials

A number of different types of cables, each with its unique set of advantages and disadvantages, are available for the transmission of electrical energy. XLPE cables are the preferred choice for secondary reticulation, among the mining industry in South-Africa. Cross-linked polyethylene insulation was developed to improve the maximum operating temperature of the cable. XLPE also has the advantages that it improves impact strength, dimensional stability, tensile strength and the resistance to aging. The construction process of an XLPE cable is very important, as poor construction can lead to impurities within the cable and will ultimately cause PD activity within the cable [10].

The different layers of a medium voltage XLPE cable can be seen in Fig. 1. Generally, a medium voltage XLPE cable will consist out of six layers. These layers include: conductor, conductor screen, XLPE insulation, insulation screen, copper screen and the outer jacket. A medium voltage XLPE cable usually has an aluminium or copper conductor. The conductor is the layer responsible for the transmission of electricity. The research will be focused on the insulation layer of the cable. Due to a number of advantages, XLPE is often the preferred option for the insulation material within medium voltage cables.

Secondary reticulation within the industrial sector is between 6.6 kV and 11 kV. From this it can be determined that the thickness of the XLPE layer of a cable, used for secondary reticulation, will range from 3 mm to 6 mm [10]. The thickness of the insulation layer as well as the relative permittivity (ϵ_r) of XLPE was used to construct a test object, from which a simple three capacitor model [11] can be derived. Typical voids within the insulation of XLPE cables have a

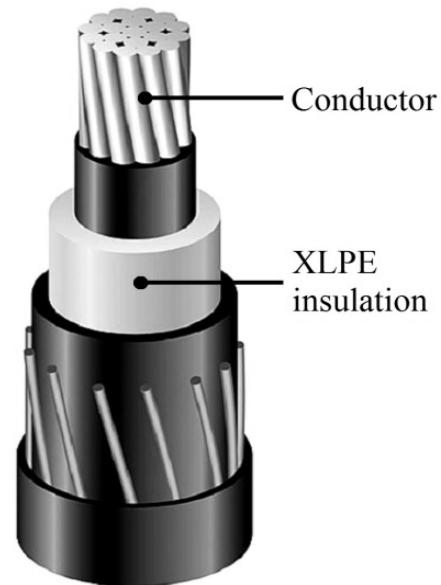

Fig. 1 Layers of a XLPE cable [10].

volume of 10 mm^3 with a height of 2-3 mm and a radius of 1-2 mm [12]. The test object, which will be used for the simulations, is shown in Fig. 2. The dimensions of the object are $30 \text{ mm} \times 30 \text{ mm} \times 6 \text{ mm}$. The volume of the void will vary for some of the simulations. The simulations discussed in this paper will be focused on PD activity due to a single void.

The three capacitor model is an electrical model used to simulate PD activity. The values for the three capacitors: C_a , C_b and C_c , shown in the three capacitor model, are calculated by means of the following equations [2]:

$$C_a = \frac{\epsilon_0 \times \epsilon_r \times (a-2r) \times b}{c} \quad (1)$$

$$C_b = \frac{\epsilon_0 \times \epsilon_r \times r^2 \times \pi}{c-h} \quad (2)$$

$$C_c = \frac{\epsilon_0 \times r^2 \times \pi}{h} \quad (3)$$

ϵ_0 = permittivity of free space;

ϵ_r = relative permittivity of XLPE;

r = radius of void (mm);

h = height of void (mm).

The determined capacitance values were used to construct the three capacitor model. The capacitor model is based on the circuit shown in Fig. 3. This model was designed to investigate the effect of PD due

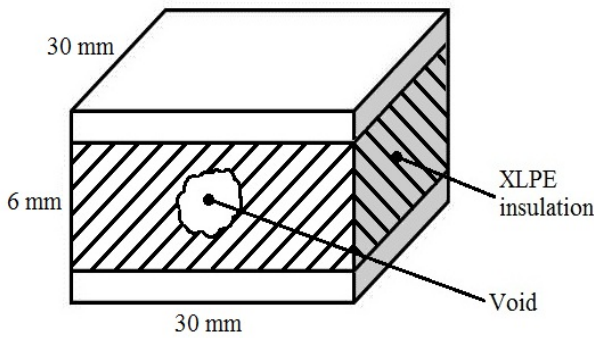

Fig. 2 Test object with a centred cylindrical void.

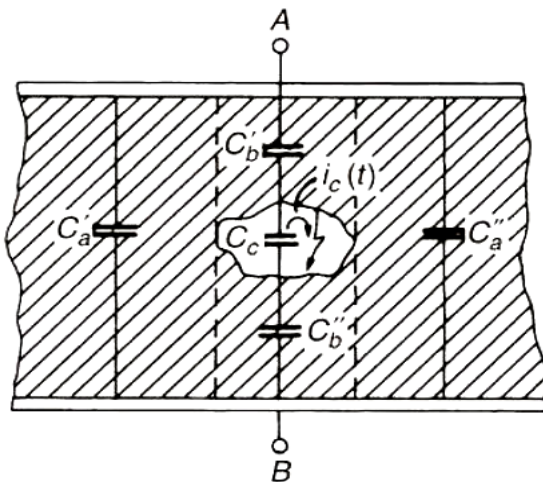

Fig. 3 Three capacitor model for PD due to voids [11].

to a single void within the insulation material of electrical cables. This model makes use of three capacitors to simulate PD activity. The first capacitor, C_c , is the capacitance value of the void. The capacitor C_b is used to represent the capacitance value of the healthy insulation close to the void. The rest of the healthy insulation is represented by the third and final capacitor, C_a . This model can be seen as a simplified model which can be used to simulate PD activity due to voids in the insulation material of an electrical cable.

2.2 Monitoring Technique

The calculated parameters as well as a number of constant values are used to simulate PD activity within the insulation of XLPE cables. A SIMULINK® model was created to simulate PD activity due to the void in the XLPE insulation material. Fig. 4 illustrates the SIMULINK® model. The model consists of a filter component (r), a measuring capacitor (C_m) and a

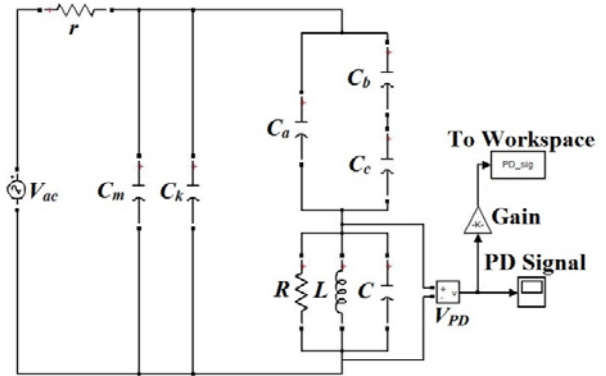

Fig. 4 PD simulation model in SIMULINK®.

coupling capacitor (C_k). The test object with the void is represented by the three capacitor model, which house the three capacitance values C_a , C_b and C_c . The measuring component of the model is connected to the circuit by means of a parallel RLC circuit. Parameters from this model were exported to the MATLAB® environment where further calculations were performed.

The main purpose of the simulations is to aid the design process of an effective non-intrusive condition monitoring technique for power cables. The operational flow of the non-intrusive condition monitoring technique is shown in Fig. 5. The first step of the condition monitoring technique is to measure the PD activity within the cable. Script files created in the MATLAB® environment is then used to analyse the collected data and also to compute a number of specific parameters. The “ q ” illustrated in Fig. 5 is the apparent charge of the measured PD signal, measured in PC. The apparent charge of the PD signal will be used to classify the discharge activity according to 5 predetermined levels of PD. The specific requirements [13] of each PD level are illustrated in Fig. 5. As can be seen from the figure, level 1 is the least significant level of PD with level 5 being the most destructive. The level of PD activity can directly be linked to the remaining operational life of the specific cable [3]. Once the level of PD is determined a specific preventive action can be taken. The preventive action can be determined by considering the approximate remaining life of the cable. Continuous monitoring is required in order for this

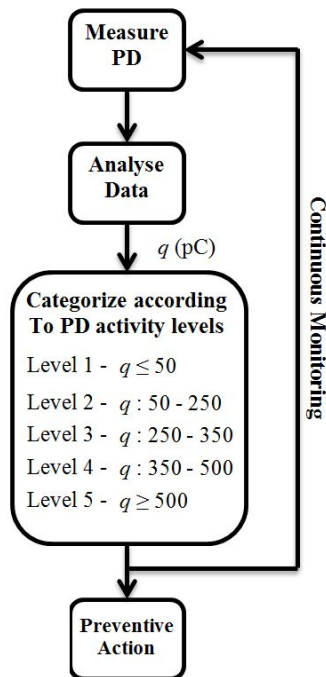

Fig. 5 Operational flow of the condition monitoring technique.

technique to be successful. The most important part of the non-intrusive condition monitoring technique is the process of classifying the discharge activity according to the 5 PD levels.

Once the PD signal is measured, it will be used to classify the discharge activity according to five different levels. The different levels will be determined by means of the maximum amplitude of the calculated apparent charge of the PD signal, as well as the number of PD pulses [3]. Level 5 will have the highest probability of cable failure. Cables with no PD activity will be classified as level 1 PD. Level 1 will include PD activity below 50 pC and generally will have no degrading effect on the insulation of a cable [13]. This means that cables classified as level 1 PD will be safe for operational purposes. When the PD is caused by stressors such as thermal, mechanical and environmental, but does not degrade the insulation, it will be classified as level 2 [3]. On-going degradation by means of these stressors will eventually cause the cable to fail. The degradation however will be at a slow rate. Level 3 PD will cause degradation of the insulation material. This is also the most unpredictable

level of PD activity and therefore it is important to re-test these cables regularly. Usually level 3 PD cables have a lifespan of more than 5 years, with some even more than 10 years [3].

Level 4 PD will result in serious degradation of the cable's insulation material and will cause definite cable failure. The general lifespan of cables classified as level 4 is 5 years or less. Some cases of level 4 PD activity can cause the cable to fail within 2 years [3]. The most severe cases of PD activity will be classified as level 5 PD. It is necessary to investigate the PD in this level by means of other measuring techniques. Level 5 discharge activity can cause an electrical cable to fail within the first year of detection. It is therefore necessary to take immediate action once this level of PD is detected in cables [13]. This classification system will form the basis of the condition monitoring technique. The measured PD signals will be classified according to the various levels and from there decisions can be made as to the severity of the PD activity and also the preventive actions to be taken.

2.3 Simulations

A number of simulations were performed in order to investigate PD due to a void in the insulation material. A constant void size of 12.57 mm³ was used for the first set of simulations. The initial input voltage of 6 kV was incremented with 0.5 kV values until the final input voltage of 11 kV was reached. The values for the parameters used in the first simulations are given in Table 1. The correlation between input voltage and maximum amplitude of the measured PD signal can be studied from these simulations. An important parameter for the classification of the PD activity according to the 5 levels is the number of PD pulses per cycle. The number of PD pulses was also obtained from this set of simulations.

The most important part of the condition monitoring technique is to obtain the apparent charge (q) of the measured PD signal. It is also important to study the correlation between the void size, within the insulation,

Table 1 Standard parameter values for simulations.

Parameter	Value
Dimensions of test object	$30 \times 30 \times 6$ (mm ³)
Input voltage	6-11 kV
Permittivity (free space) (ϵ_0)	8.854×10^{-12}
Relative permittivity (ϵ_r)	2.3
Radius of void (r)	1 (mm)
Height of void (h)	4 (mm)
C_a	2.8510×10^{-12} (F)
C_b	3.1988×10^{-14} (F)
C_c	6.9539×10^{-15} (F)

and the apparent charge of the measured PD signal. To be able to study this correlation the second set of simulations was done with a constant input voltage of 6 kV and a void size varying between 12 mm³ and 315 mm³.

The apparent charge of the measured PD signal is determined by means of the following equation [2]:

$$q = C_b \times V_c \quad (4)$$

q = apparent charge of measured PD (pC);

C_b = capacitance value of area closest to void (F);

V_c = voltage across void capacitor (V).

The apparent charge of the measured PD signal is used, due to the fact that an accurate measurement of the actual PD signal is not possible.

3. Results

The various sets of simulations were used to investigate PD at different values of the input voltage as well as for different sizes of a single cylindrical void in the insulation. The measured PD signal at an input voltage of 6 kV and with a void size of 12.57 mm³ is shown in Fig. 6. The measured signal for each specific simulation was exported to MATLAB[®] in order to perform the necessary calculations. The signal represented in Fig. 6 is without noise and thus only gives data of the simulated PD activity within the cable. The practical model will obtain a similar signal when performing measurements. The measured signals will then be processed exactly the same as the simulated signals.

For the second set of simulations the volume of the void (V) must vary between 12 mm³ and 315 mm³. This

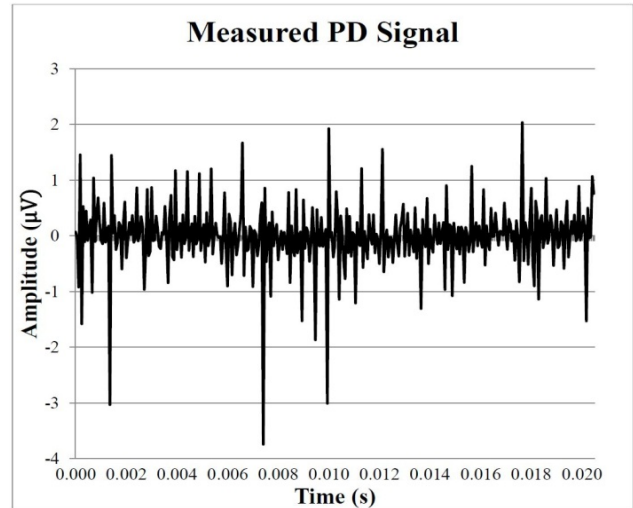
**Fig. 6** Measured PD signal at 6 kV.

was done by using a constant height (h) of 4 mm and increasing the radius (r) from 1 mm to 5 mm. The calculated volume values are shown in Table 2.

The capacitance values used within the three capacitor model will vary, due to the fact that the void size for the second set of simulations will not be kept constant. Eqs. (1)-(3), were used to calculate the values for C_a , C_b and C_c . The calculated capacitance values for the void sizes are shown in Table 3.

The calculated results from Tables 2 and 3 were used to perform the PD simulation by means of the SIMULINK[®] model. Data obtained from the SIMULINK[®] was analysed by means of a script file created in the MATLAB[®] environment and yielded the results shown in Table 4. These results are used to investigate specific parameters which are used to classify the PD activity within the cable according to the five levels. The two most important data sets shown in Table 4 include the PD pulses as well as the apparent charge (q) of the measured PD signal.

As mentioned, the number of PD pulses per cycle (0.02 s) is an important parameter used for the classification of the measured PD activity. The number of pulses, for an input voltage of 6-11 kV ranged between 120 and 128 pulses. A graph illustrating the number of pulses per cycle is shown in Fig. 7. Due to the random nature of PD activity it is difficult to predict the number of pulses for an input voltage.

Table 2 Calculated void volume values.

r (mm)	h (mm)	V (mm ³)
1	4	12.566
2	4	50.265
3	4	113.09
4	4	201.06
5	4	314.15

Table 3 Calculated capacitance values.

V (mm ³)	C_a (pF)	C_b (pF)	C_c (pF)
12.566	2.851	0.03199	0.00695
50.265	2.647	0.12780	0.02782
113.09	2.444	0.28790	0.06259
201.06	2.240	0.51180	0.11130
314.15	2.036	0.79970	0.17390

Table 4 Calculated results.

V_{in} (kV)	PD pulses	V (mm ³)	C_b (pF)	V_a (V)	q (pC)
6	120	12.566	0.031	381.1940	10.01
7	126	50.265	0.128	381.1949	40.06
8	123	113.09	0.288	381.1960	90.14
9	123	201.06	0.512	381.1995	160.2
10	124	314.15	0.799	381.1910	250.4

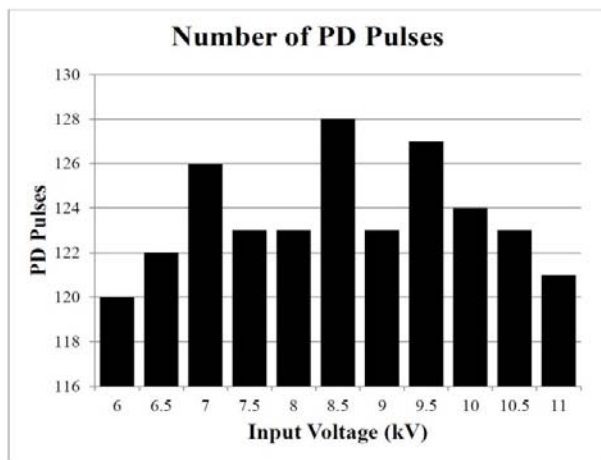

Fig. 7 Graph depicting number of PD pulses per cycle.

It is important to obtain accurate measurements for the number of PD pulses per cycle, in order to successfully classify the PD activity according to the five levels. The best way to obtain accurate values for the number of PD pulses is to obtain a base value of the operational environment of the cable. This can then be used to eliminate external noise from the actual measurements. The elimination of noise can significantly improve the accuracy of the condition monitoring technique.

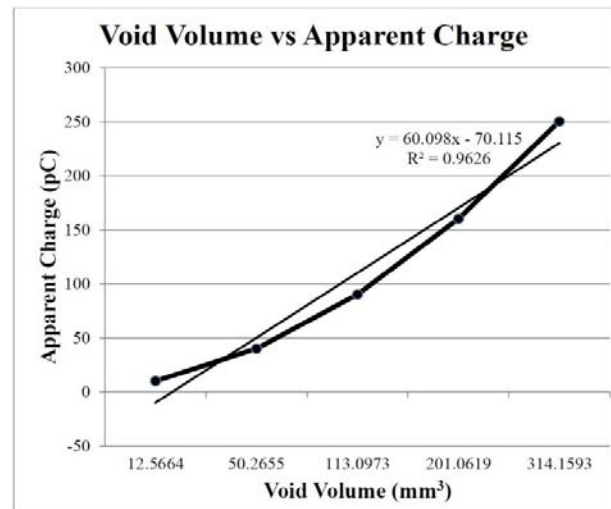

Fig. 8 Graph of void volume vs apparent charge.

The most important parameter obtained from the simulation results is the apparent charge (q) of the measured PD signal. The apparent charge will eventually be used to classify the PD activity within a specific cable according to the five predetermined levels of PD activity. The correlation between void size and apparent charge of the measured PD signal was also studied by means of the graph illustrated in Fig. 8.

From this graph, it can be seen that the correlation between void volume and the apparent charge of the measured PD signal is almost linear. In Fig. 8, it can be seen that the R^2 value is 0.9626. Due to the fact that this value is close to 1 it can be said that the assumed trendline or the fitted trendline is a very close approximation to the actual values. By studying the correlation between the volume of the void and the apparent charge the conclusion can be made that a void with a bigger volume will cause more severe PD activity within the XLPE cable. Measured values for the apparent charge of the PD signal as well as the formula of the trendline $y = 60.098x - 70.115$ can be used to determine an approximate value for the volume of the void within the cable's insulation material.

From the results discussed in this section, the discharge activity within a specific cable can be classified according to the five PD levels. The five levels of PD activity can directly be linked to the remaining life of a cable. This information can be used

to determine a preventive action for each level of PD. Once a void with significant size appears within the insulation material of a cable, it will grow to the point where the PD activity, due to the void will cause degradation to the point of cable failure. Premature cable failure can thus be prevented by means of successful analysis of the results discussed within this section of the paper.

4. Conclusions

Various conditions will contribute to the degradation of the insulation material of electrical cables. Partial discharge is the main cause for degradation of insulation materials used within electrical cables. The degradation will continue until the point of cable failure. Due to the disadvantages accompanied with premature failing of cables it is important to continuously monitor the condition of electrical cables.

The simulation results discussed in this paper were used as the first steps in developing a non-intrusive condition monitoring technique. The development of this technique is still in the design phase and therefore various aspects of PD activity still needs to be investigated and then incorporated in the final design of the cable condition monitoring technique. The condition monitoring technique will be based on the measuring and classification of discharge activity according to five predetermined levels of PD. An approximate remaining operational life is determined for each level of PD activity and then used to identify the appropriate preventive action for the specific level of PD activity. The condition monitoring technique makes use of both the number of PD pulses per cycle, as well as the apparent charge of the measured PD signal to classify the PD activity according to one of the five levels. The classification criteria of the monitoring technique can be updated to comply with one of the IEEE standards. The best suited for the project is IEEE std 400TM-2001, the IEEE Guide for Field Testing and Evaluation of the Insulation of Shielded Power Cable Systems [14]. The main purpose

of this guide is to provide an overview of the various tests available for evaluating the insulation of cable systems in the field. The guide also has a specific section on PD testing, with the main focus on PD fundamentals, partial discharge characterization and also the measurement of PD activity. It is important to adapt the current classification criteria to this IEEE standard in order for the final product to be accurate and to be able to obtain relevant data.

At the moment, the simulation model shown in Fig. 4 does not incorporate the high frequency model of a power cable. This has a direct and significant influence on PD magnitude. It is therefore critical that future work will include the incorporation of the high frequency model of the power cable in the simulation model. This will lead to the simulation results being more accurate when compared to actual measured results. Future work will also include an in depth study of the statistical nature of PD activity. At the moment, a more comprehensive three capacitor model is being designed to incorporate these elements of partial discharge activity into the simulations.

The project research and results obtained from simulations will be used for the design, construction and implementation of a practical model. This model will be used for non-intrusive condition monitoring of power cables by means of PD measurements. The results obtained from measurements taken by the practical model can be compared to that of simulation results. This then can be used to validate the accuracy of the constructed model.

References

- [1] J.R. Lucas, High voltage engineering, Department of Electrical Engineering, University of Moratuwa, Sri Lanka, revised edition, 2001.
- [2] A. Sabat, S. Karmakar, Simulation of partial discharge in high voltage power equipment, International Journal on Electrical Engineering and Informatics 3 (2011) 234-247.
- [3] N. Ahmed, N. Srinivas, Partial discharge severity assessment in cable system, in: Transmission and Distribution Conference and Exposition, Atlanta, 2001, pp. 849-852.

- [4] G. Chen, F. Baharudin, Partial discharge modelling based on a cylindrical model in solid dielectrics, in: International Conference on Condition Monitoring and Diagnosis, Beijing, China, Apr. 2008.
- [5] R. Lofaro, M. Villaran, Essential Elements of an Electric Cable Condition Monitoring Program, Brookhaven National Laboratory, NY, 2010, pp. 62-96.
- [6] D.A. Nattrass, Partial discharge XVII the early history of partial discharge research, Electrical Insulation Magazine, IEEE 9 (4) (1993) 27-31.
- [7] A. Haddad, D. Warne, Advances in High Voltage Engineering, The Institution of Engineering and Technology, United Kingdom, revised edition, 2007.
- [8] F. Haghjoo, E. Khanahmadloo, S.M. Shahrtash, Comprehensive 3-capacitor model for partial discharge in power cables, COMPEL: The International Journal for Computation and Mathematics in Electrical and Electronic Engineering 31 (2) (2012) 346-368.
- [9] G. Paoletti, A. Golubev, Partial discharge theory and applications to electrical systems, Pulp and Paper: Industry Technical Conference Record, Seattle, June 21-25, 1999, pp. 124-138.
- [10] I.A. Metwally, High-voltage power cables plug into the future, IEEE Potentials 27 (1) (2008) 18-25.
- [11] M.F. Badillo, L.N. Navarrete, A.G. Parada, A.C. Miranda, Simulation and analysis of underground power cable faults, in: International Meeting of Electrical Engineering Research, Ensenada, Mexico, Apr. 2012, pp. 50-57.
- [12] C.Y. Ren, Y.H. Cheng, P. Yan, Y.H. Sun, T. Shao, Simulation of partial discharge in single and double voids using SIMULINK[®], in: 27th International Conference Record of the Power Modulator Symposium, Arlington, May 2006, pp. 120-123.
- [13] Emerson, Partial Discharge Testing for Cables, Electrical Reliability Services, Columbus, Ohio, Dec. 2008.
- [14] IEEE Power Engineering Society, IEEE std 400TM-2001, The Institute of Electrical and Electronics Engineers Inc., NY, Jan. 2002, pp. 13-15.