

Case Study of Indirect Adiabatic Cooling System in Historical Building

Artūrs Brahmanis, Arturs Lešinskis and Andris Krūmiņš

Water, Heat and Gas Technology Institute, Riga Technical University, Riga LV-1048, Latvia

Received: October 06, 2013 / Accepted: November 18, 2013 / Published: February 28, 2014.

Abstract: The objective of the present study is to investigate the efficiency of indirect adiabatic chiller-based cooling system efficiency dependence of outdoor air humidity. The system is located in historical building, in temperate climate of Latvia. The data about electricity consumption, water consumption, chiller operation stages, cooling average temperatures and outdoor air parameters have been acquired for the period of 2.5 month, during the cooling season. Using data collected by BACnet based BMS controllers and adiabatic chiller control system, we have analyzed operation efficiency of the chiller and its dependence of outdoor air humidity. Data range for the period from August 1st till October 13th, 2011 was taken for deeper analysis, which showed that in temperature range 22.0 ± 0.5 °C for the studied period of time chiller's COP is slightly dependent on the outdoor air moisture.

Key words: Indirect evaporative, cooling, historical building.

1. Introduction

Restoration of old buildings is a complex construction process, in which engineers and architects need to solve many atypical tasks concerning not only the structural stability of the building, but also the recovery of cultural — historical appearance of the building. Torres et al. in their study [1] pointed that one of important issues of the old buildings is high moisture in its structures, which among other things, also depends on correct indoor air parameters maintenance. Necessity of harmonious integration of modern HVAC devices in the historical interior also enforces limits to the equipment selection. Solving these construction tasks successfully results in a balanced and sustainable restoration of the whole building.

Present building of the Riga Bourse was initially built in the 19th century. The building had an eventful history, several fires, but preserved its original appearance. Nowadays, it was completely restored, and opened as an

art museum in summer 2011. To preserve artefacts, the museum is equipped with climate control and building management systems. Building is located in the centre of historical part of Riga (Old Riga), Fig. 1.

Evaporative cooling in buildings is not commonly used in Baltic region, due to high air moisture content, which considerably reduces cooling efficiency of water evaporation process. Costelloe and Finn [2] mentioned that, while water side evaporative cooling arrangements are occasionally used, with air-water systems, particularly in more arid climates, the use of



Fig. 1 The Riga bourse building after restoration.

Corresponding author: Artūrs Brahmanis, Ph.D. candidate, research fields: HVAC systems and equipment, design and applications. E-mail: arturs.brahmanis@rtu.lv.

the technique falls far short of its potential. This is particularly the case in west European temperate climates where many opportunities to benefit from evaporative cooling techniques are often overlooked. This situation is attributed by field to a lack of in-depth knowledge of the energy performance of water side free cooling systems, in terms of the cooling generated per unit of primary energy expended [2]. However, the present engineering tendencies shows that, due to the development of HVAC system and control equipment, this method of cooling becomes even more attractive for use also in European countries with temperate climates.

2. Cooling System Description

Cooling system in the museum consists of indirect evaporative water chiller with integrated compressor,

five air handling units with cooling/dehumidifying coils and 98 fan-coil units on separated loop (Fig. 2).

Those museum premises, which are used for storing the most valuable exhibits, are equipped also with autonomous air humidifiers to keep air moisture level in winter seasons [2]. Cooling unit consists of two parts, one of which contains hydraulic components, fan and compressor cycle elements. Second part encloses cross flow air-water heat exchanger with water nozzles for adiabatic cooling of outdoor air, as shown in Fig. 3.

3. Methods

Outdoor air parameters have been acquired also by the building’s air handling units’ automatics and incidentally, in some cases slightly (o.a. temperature about + -2 °C) differs from the chiller sensors readings. We have ignored those deviations and took into

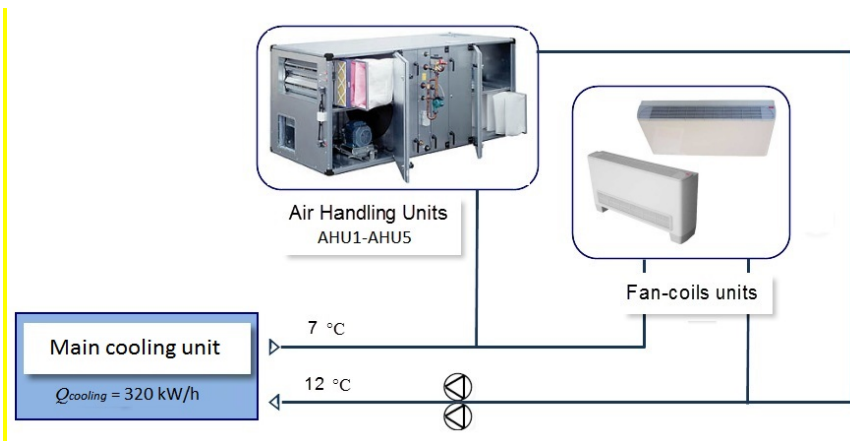

Fig. 2 Simplified cooling system schematic diagram.

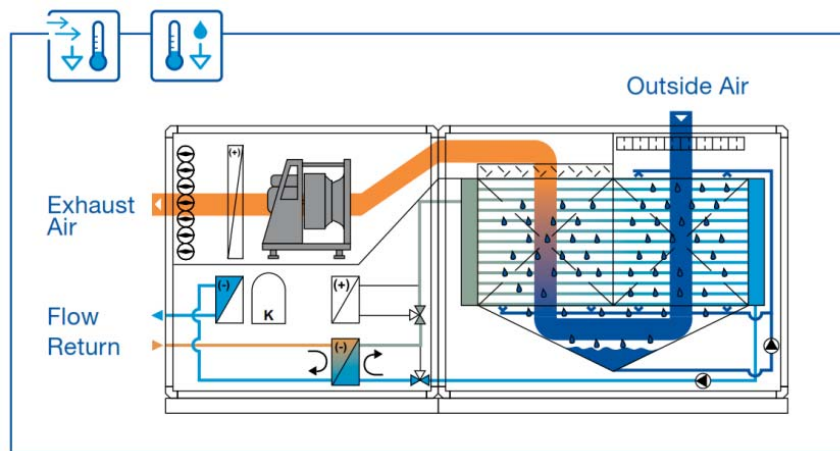

Fig. 3 The chiller operation scheme during “adiabatic” cycle [8].

account only data collected by chiller's sensors, due to the fact, that these data are determinative for the unit automatics. As a measure of the chiller operating efficiency relation to the outdoor air moisture content, we have used the unit COP (coefficient of performance) and intake air absolute humidity ratio at relatively constant temperatures. Data storing server recorded operation data every minute, including intake air temperature, relative humidity, in/out cooling liquid flow in primary loop, energy and water meters readings.

Knowing altitude and air temperature, saturation humidity ratio W_s can be found [2], using equation:

$$W_s = 0.62198 \frac{p_{ws}}{p - p_{ws}} \quad (1)$$

where,

W_s = saturation humidity ratio, kg_w/kg_{da};

p_{ws} = saturation pressure, kPa;

p = barometric pressure, kPa.

The barometric pressure is assumed as function of altitude Z , which is 6 m average for the Old Riga:

$$p = 101.325(1 - 2.25577 \times 10^{-5}Z)^{5.2559} \quad (2)$$

The saturated vapor pressure in kPa is calculated, using [6] Magnus formula:

$$p_{ws}(t) = \alpha \exp\left(\frac{\beta * t}{\lambda + t}\right) \quad (3)$$

where,

t = air temperature, °C;

$\alpha = 0.6112$, kPa;

$\beta = 17.62$;

$\lambda = 243.12$, °C.

Using intake air relative humidity data acquired, air moisture content was obtained:

$$x = \varphi W_s \quad (4)$$

where,

φ = relative humidity, dimensionless.

The formulas above concerns to intake air psychrometrics. Turning to equipment efficiency evaluating, we've calculated cooling energy produced by chiller per minute, using Eq. (5) [7].

$$Q = g * \rho * c_{cw}(T_{in} - T_{out}) \quad (5)$$

where,

Q = cooling output, kW/min;

g = cooling fluid volumetric flow, m³/min;

ρ = cooling fluid density, kg/m³;

c_{cw} = cooling fluid specific heat, kJ/kg/K.

Cooling fluid in the system is 35% ethylene-glycol and water mixture, $\rho = 1.045$ kg, $c_{cw} = 3.585$ kJ/kg/K. The chiller COP according to energy balance equation will be:

$$\text{COP} = \frac{\text{Cooling power}}{\text{Input power}} \quad (6)$$

The input power was calculated for each hour of analyzed period, using electricity meter data (every 60th min minus every 1st minute of each hour).

4. Results

Electricity consumption, water consumption, chiller operation stages, fluid temperatures and outdoor air parameters data have been acquired for the period from August 1st till October 13th, 2011 (the cooling system launched at 1st of August 2011). Using data acquired by BACnet based BMS controllers and experimental data logging system, we have analyzed efficiency of indirect adiabatic process and its dependence of outdoor air humidity. We have chosen the last week of August, as the warmest weather occurred in this period during the unit operation in 2011. Saved data has been exported as CSV files and after sorting with Excel Pivot Table functions imported in Matlab/Simulink software for graphical visualization. An air intake temperature in range from 21.5 °C to 22.5 °C was logged during 1,038 min and it was the most frequent case in the analyzed period (Fig. 4):

Matlab visualization showed that cooling unit COP dependence of outdoor air moisture content is clearly visible, when air temperature is not taken into account (Fig. 5). It is obvious, because absolute humidity changes sharply according to the temperature.

Data analysis in temperature range 22.0 ± 0.5 °C showed that for the studied period of time chiller's COP very slightly dependent on the outdoor air moisture,

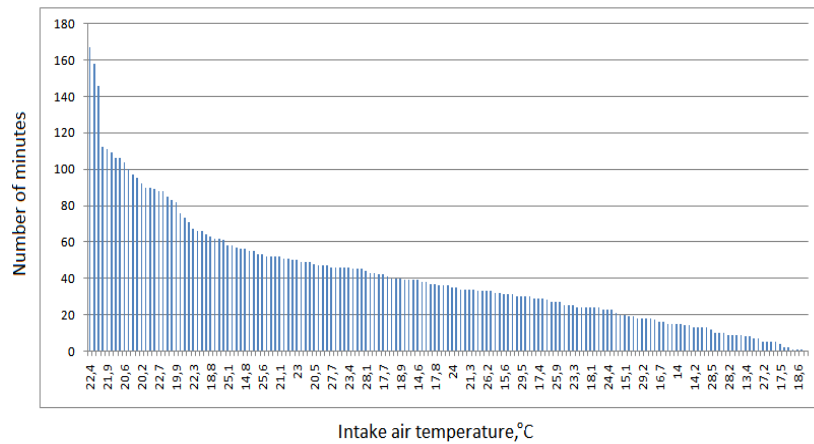

Fig. 4 Number of temperature—minutes during the August 24-31, 2011.

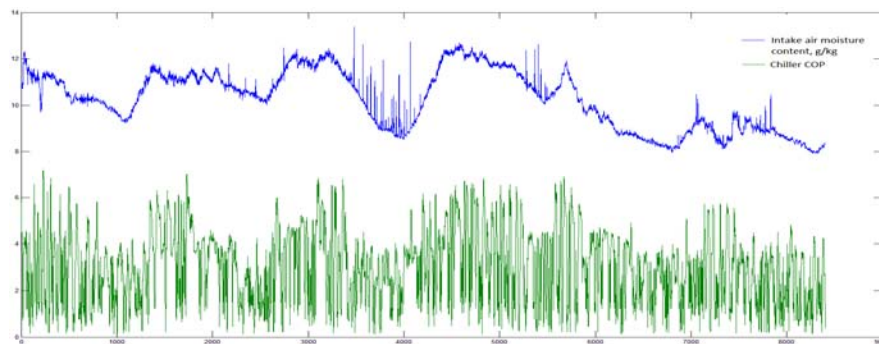

Fig. 5 Intake air moisture content and chiller’s COP during 140 h operation.

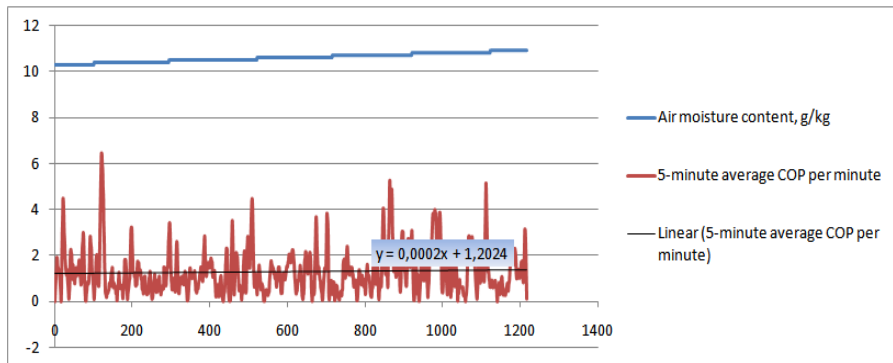

Fig. 6 Intake air moisture content and chiller’s COP during operation within constant temperature.

which shows graph in Fig. 6. These changes could be expressed linearly by equation $y = 0.0002x + 1,2024$.

5. Conclusions

Electricity consumption, water consumption, chiller operation stages, cooling average temperatures and outdoor air parameters data have been acquired for the period of 2.5 month, during the first cooling season of a system.

Data range for the period from August 21st till August 31th, 2011, was selected for deeper analysis as the hottest week in operation season.

Data analysis in constant temperature 22.0 ± 0.5 °C shows that for the studied period of time chiller’s COP very slightly depends on the outdoor air moisture, and contrary to our expectations this dependence is direct proportional. This effect could be related to increasing of outdoor air heat assimilation ability due to higher

specific heat, which leads to rising of refrigerant—air heat exchanger efficiency. We feel that this case requires further investigation, using more data points with constant temperatures, as well as different temperatures—COP relation comparison and analysis.

The results of the present and related studies will clarify the efficiency of indirect adiabatic cooling systems in temperate climates.

References

- [1] M.I.M. Torres, V.P. Freitas, Treatment of rising damp in historical buildings: Wall base ventilation, *Building and Environment* 42 (2007) 424-435.
- [2] B. Costelloe, D. Finn, Indirect evaporative cooling potential in air-water systems in temperate climates, *Energy and Buildings* 35 (2003) 573-591.
- [3] A. Krumins, A. Brahmanis, A. Lesinskis, U. Pelite, Optimal control strategy of air handling unit for different microclimates in working and swimming areas of a swimming pool hall, in: *The 11th International Conference on Indoor Air Quality and Climate*, Denmark, Copenhagen, Aug. 17-22, 2008, pp. 173-180.
- [4] A. Brahmanis, A. Lešinskis, Indirect evaporative pre-cooled compressor cooling system performance under various outdoor air humidity conditions, in: *Conference "Civil Engineering 13"*, Jelgava, Latvia, 2013, p. 5.
- [5] Chilled water units for process and climate cooling, <http://www.menerga.com/HybriTemp-Type-97-98.159.0.html?&L=2>.
- [6] *ASHRAE Handbook—Fundamentals*, American Society of Heating, Refrigerating and Air-Conditioning Engineers, 2001.
- [7] SENSIRION Introduction to relative humidity Web site, Version 2.0. Aug., 2009, p. 6, <http://www.sensirion.com/>.
- [8] J.F. Krieder, *Handbook of Heating Ventilation and Air Conditioning*, CRC Press, 2001, pp. 216-217.